

Rio5

ADDENDUM - SUGGESTED WIRING CONFIGURATION SCHEMA DE BRANCHEMENT SUGGERE

VEHICLES VEHICULES		YEARS ANNÉES	Lock	Unlock	Arm	Disarm	Hatch (open)	Trunk (open)	Sliding Door	Window Roll Down	Gas Door	RAP Disable	Parking Lights	Memory Driver	Tachometer	Defrost	Heated Seats	Heated Mirrors	Rear Defrost	Door Status	Trunk Status	Hood Status	Hand-Brake Status	Foot-Brake Status	Transponder Bypass	PK3, Passlock	Key Control	Activate OEM Remote	Start	Push-to-Start Control	SEE LEGEND
KIA			A	B	C	D	E	F	G	H	I	J	K	L	M	N	O	P	Q	R	S	T	U	V	W	X	Y	Z	ZA	ZB	
Rio5	or ou	Reg.Key 2012-2013																													
Rio5		Reg.Key 2012-2013																													

	HARDWARE VERSION VERSION DU MATERIEL Minimum 3	FIRMWARE VERSION VERSION DU LOGICIEL Minimum 4.02
--	---	--

2 OBD-II connector.
Connecteur OBD-II

1 **3** Left of steering column - Junction Box
Gauche de la colonne de direction - Boîte de jonction

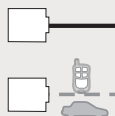
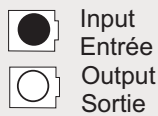
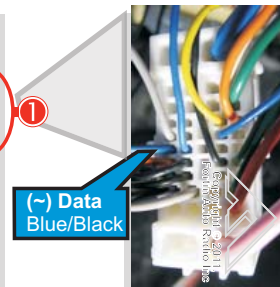
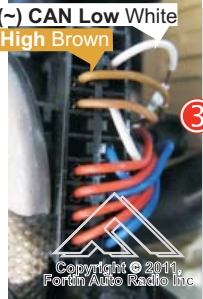

Connection always **required**
Branchement toujours **requis**

Connection **not required** with Data-link
Branchement **non requis** avec Data-Link



Connect to vehicle
Branchement au véhicule



Connect to Remote-Starter/Alarm
Branchement au démarreur à distance/Alarme

**INSTALLATION WITH DATA-LINK
INSTALLATION AVEC DATA-LINK**

Remote Starter/Alarm with the Fortin Data-link protocol.
Démarreur à distance/alarme avec le protocole Data-link Fortin

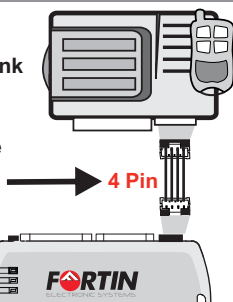

**INSTALLATION WITHOUT DATA-LINK
INSTALLATION SANS DATA-LINK**

Remote Starter/Alarm Démarreur à distance/alarme

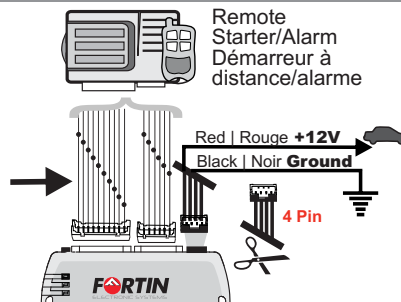

- 1 Cut off one plug of the 4 Pin Data-Link connector
- 2 Connect the Red wire to +12V
- 3 Connect the Black wire to Ground

- 1 Coupez l'extrémité du connecteur 4 pins Data-Link
- 2 Connectez le fil rouge au 12V
- 3 Connectez le fil noir à la masse du véhicule.

CONNECTION GUIDE

KIA RIO 2012

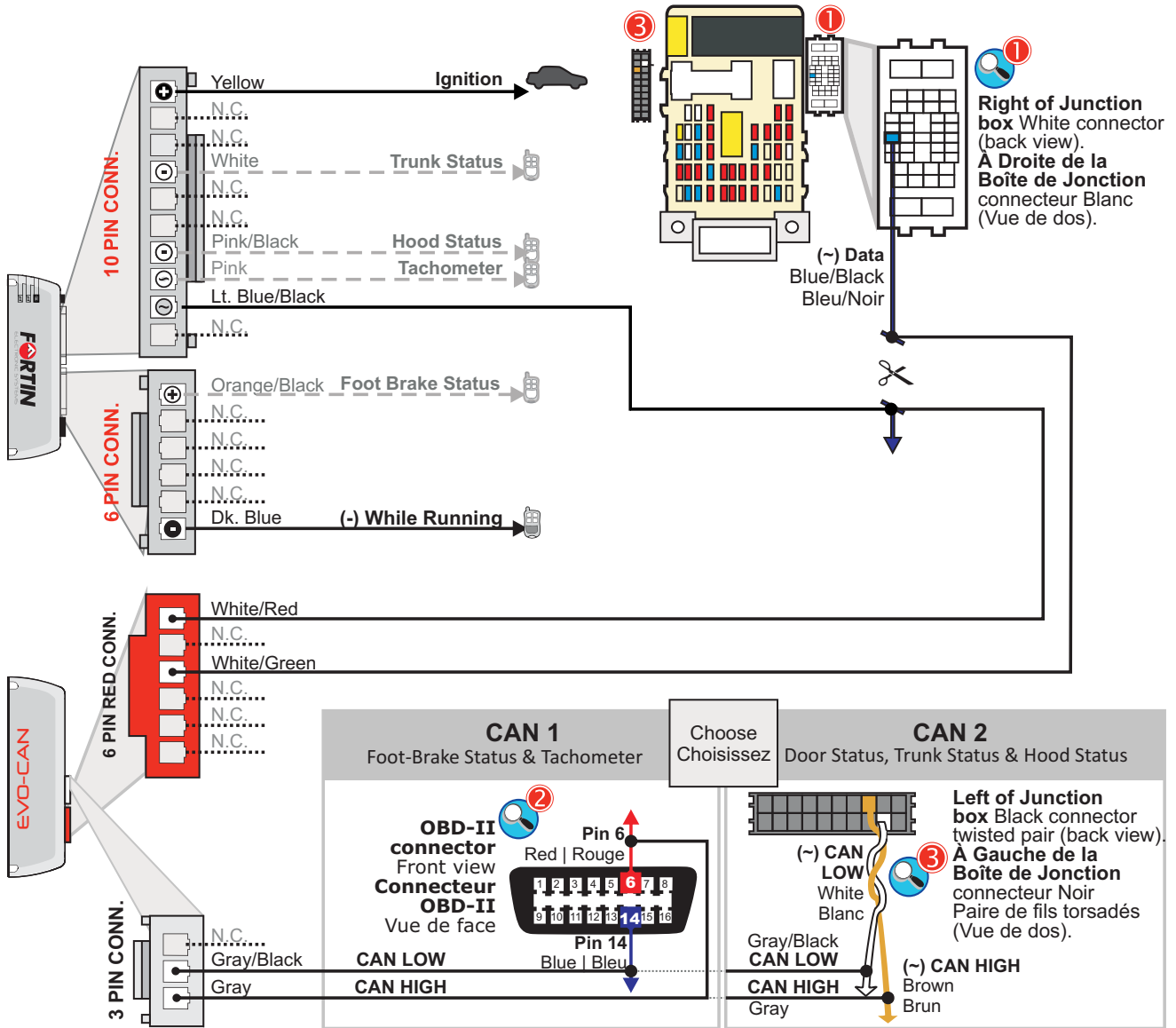

PROGRAMMING PROCEDURE | PROCÉDURE DE PROGRAMMATION

1



Press and hold the programming button:

Appuyez et maintenez enfoncé le bouton de programmation:

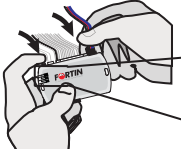

Insert the 4 Pin (Data-Link) connector.

Insérez le connecteur 4 pins (Data-Link).

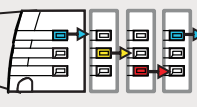

The LED's will alternate between **BLUE, YELLOW and RED** flashes.

Les DELS alternent entre un flash **BLEU, JAUNE et ROUGE.**

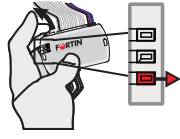

Release the programming button when the LED is **RED.**

Relâchez le bouton de programmation quand la DEL est **ROUGE.**

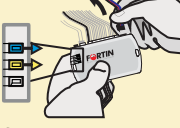

If the LED is not solid RED disconnect the 4 Pin connector (Data-Link) and go back to step 1.

Si le DEL n'est pas ROUGE solide débranchez le connecteur 4 pins (Data-Link) et allez à l'étape 1.

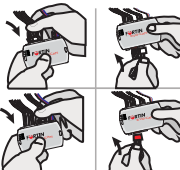

Insert the remaining required connectors:
10 pin (White), 2 pin (White), 6 pin (White), 6 pin (Red), 3 pin (White).

Insérez les connecteurs requis restants:
10 pins (Blanc), 2 pins (Blanc), 6 pins (Blanc), 6 pins (Rouge), 3 pins (Blanc).

2 **3**



Press and release the programming button once (1x).

Appuyez et relâchez 1 fois le bouton de programmation.

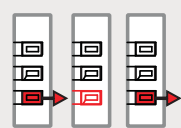

The **RED LED** will turn OFF and then back ON

La DEL ROUGE s'éteint et se rallume.



Press and release the programming button six (6x) times.

Appuyez et relâchez 6 fois le bouton de programmation.

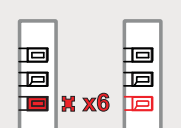

The **RED LED** will flash 6 times each second.

La DEL ROUGE clignote 6 fois chaque seconde.



Turn the Ignition to the ON/RUN position.

Tournez la clef en position **ignition (ON).**



The **RED LED** will flash rapidly 10x times. Key bypass programmed.

La DEL ROUGE clignotera 10x fois rapidement.

Contournement de clé programmé.

With CAN wires connected:
Avec les fils de CAN branchés:

CAN 2

Door Status, Trunk Status & Hood Status

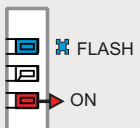

The **Blue LED** will flash rapidly: Door Status, Trunk Status and Hood Status programmed.

La DEL BLEU clignotera rapidement : Statut de Porte(s), Statut de valise et Statut de capot programmé.

CAN 1

Foot-Brake Status & Tachometer

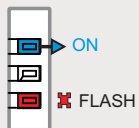

The **RED LED** will flash rapidly: Foot-Brake and Tach programmed.

La DEL ROUGE clignotera rapidement: Pédale de frein et Tach programmé.



Turn the Ignition to the OFF position.

Tournez la clef à OFF.

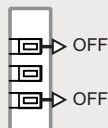

The LEDs will turn OFF.

Les DEL s'éteignent.



The module is now programmed.

Le module est programmé.

Use the remote of the remote starter or security system to test all of the supported features to ensure proper programming.
Testez toutes les fonctions supportées sur le véhicule avec la télécommande du démarreur à distance ou du système de sécurité.

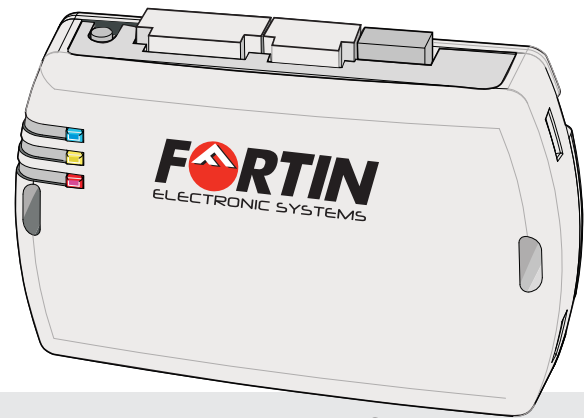

Module label | Étiquette sur le module

Notice: Updated Firmware and Installation Guides

Updated firmware and installation guides are posted on our web site on a regular basis. We recommend that you update this module to the latest firmware and download the latest installation guide(s) prior to the installation of this product.

Des mises à jour du Firmware (microprogramme) et des guides d'installation sont mises en ligne régulièrement. Vérifiez que vous avez bien la dernière version logiciel et le dernier guide d'installation avant l'installation de ce produit.

WARNING / TECH SUPPORT / MISE EN GARDE / SUPPORT TECHNIQUE

The information on this sheet is provided on an (as is) basis with no representation or warranty of accuracy whatsoever. It is the sole responsibility of the installer to check and verify any circuit before connecting to it. Only a computer safe logic probe or digital multimeter should be used. FORTIN ELECTRONIC SYSTEMS assumes absolutely no liability or responsibility whatsoever pertaining to the accuracy or currency of the information supplied. The installation in every case is the sole responsibility of the installer performing the work and FORTIN ELECTRONIC SYSTEMS assumes no liability or responsibility whatsoever resulting from any type of installation, whether performed properly, improperly or any other way. Neither the manufacturer or distributor of this module is responsible of damages of any kind indirectly or directly caused by this module, except for the replacement of this module in case of manufacturing defects. This module must be installed by qualified technician. The information supplied is a guide only. This instruction guide may change without notice. **Visit www.fortinbypass.com to get the latest version.**

L'information de ce guide est fournie sur la base de représentation (telle quelle) sans aucune garantie de précision et d'exactitude. Il est de la seule responsabilité de l'installateur de vérifier tous les fils et circuit avant défectuer les connections. Seule une sonde logique ou un multimètre digital doivent être utilisés. FORTIN SYSTÈMES ÉLECTRONIQUES n'assume aucune responsabilité de l'exactitude de l'information fournie. L'installation (dans chaque cas) est la responsabilité de l'installateur effectuant le travail. FORTIN SYSTÈMES ÉLECTRONIQUES n'assume aucune responsabilité suite à l'installation, que celle-ci soit bonne ou mauvaise ou de n'importe autre type. Ni le fabricant, ni le distributeur ne se considèrent responsables des dommages causés ou ayant pu être causés, indirectement ou directement, par ce module, excepté le remplacement de ce module en cas de défectuosité de fabrication. Ce module doit être installé par un technicien qualifié. L'information fournie dans ce guide est une suggestion. Ce guide d'instruction peut faire l'objet de changement sans préavis. **Consultez le www.fortinbypass.com pour voir la plus récente version.**

Copyright © 2006-2011, FORTIN AUTO RADIO INC ALL RIGHTS RESERVED **PATENT PENDING**



TECH SUPPORT

Tél: 514-255-HELP (4357)
1-877-336-7797



ADDENDUM GUIDE

www.fortinbypass.com

WEB UPDATE | MISE À JOUR INTERNET

